

High Efficiency, Synchronous Boost Charger for Two/Three-cell Li-ion Battery with Cell Balance and Power Path Management Function

1 DESCRIPTION

The SC8922 is a highly integrated switch-mode boost charger and system power path management device for 2/3 cells Li-ion battery applications. It is able to step up 4.5V~5.5V input voltage to up to 16V, and provide battery charge management functions including trickle charge, constant current charge, constant voltage charge, charge termination and charging status indication. Besides that, the IC can also provide cell balance function, so to reduce the cell voltage mismatch and increase the battery life time.

The SC8922 supports up to 3A charge current, and the user can program the current freely through external resistor for different applications. With the power path management function and supplement mode, the IC can be used to charge 2/3 cells Li-ion battery and meantime provide power for system operation.

The SC8922 supports input current limit, input under voltage and over voltage protections, internal cycle by cycle current limit, battery short circuit protection, and output over voltage protection. It also offers charging safety timer, battery cell temperature monitor and over temperature protection to ensure safety under different abnormal conditions.

The SC8922 is available in 4x4 QFN-24 package.

3 APPLICATIONS

- Blue tooth speaker charger
- E-joy charger
- LI-ion battery charger
- POS machine

4 DEVICE INFORMATION

Part Number	Package	Dimension
SC8922QDLR	QFN-24	4 mm x 4 mm x 0.75 mm

2 FEATURES

- Integrated Synchronous Boost Charger
- Integrated Power Path Management
- Cell Balance Function
- Charging Management (Trickle Charge / Constant Current Charge / Constant Voltage Charge / Charge Termination)
- Programmable Constant Charge Current
- Programmable Constant Voltage
- Charge Status Indication
- Charge Safety Timer
- NTC for Battery Protection
- 2A / 3A Input Current Limit Option
- Adaptive Input Current Limit
- Input Under Voltage and Over Voltage Protection
- Battery Short Circuit Protection
- Thermal Shutdown

5 Typical Application Circuit

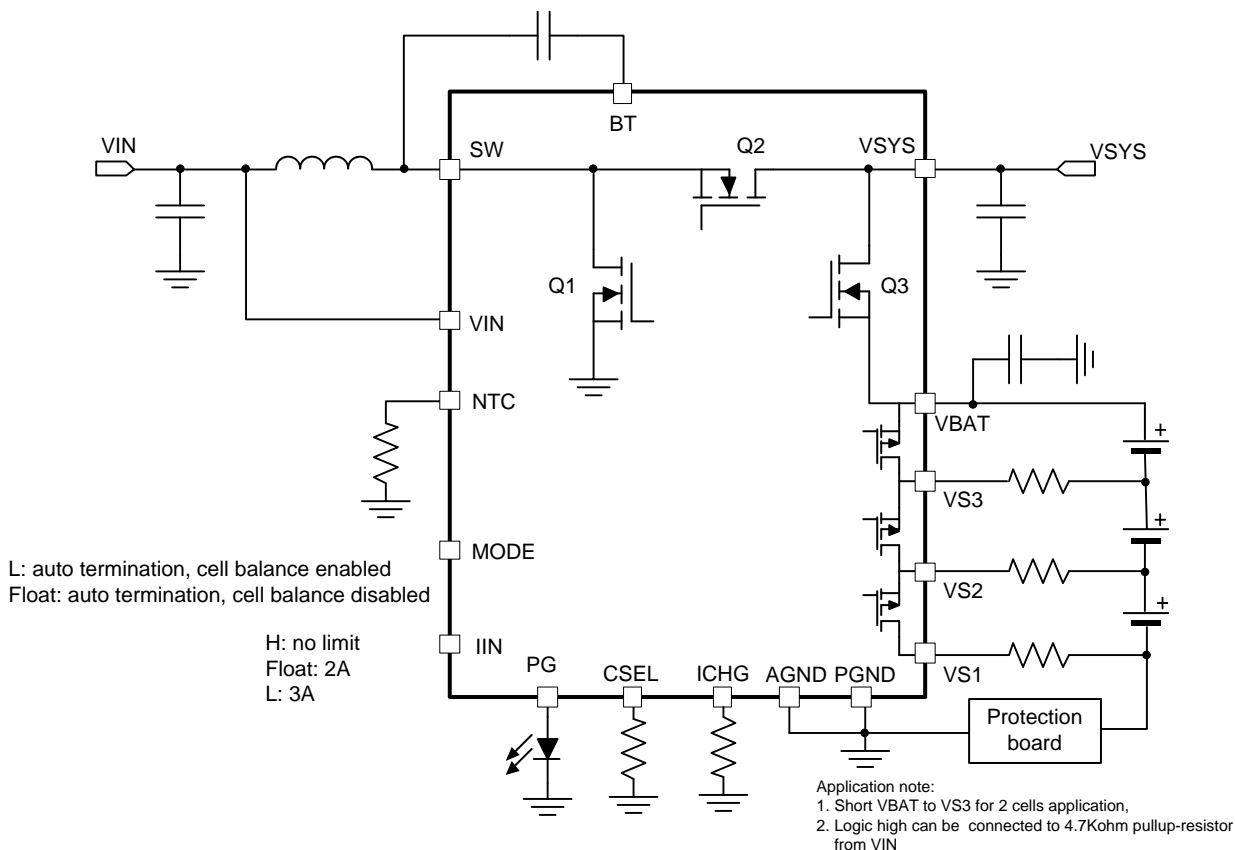

6 Selection Guide

Part Number	VIN range	Max. VBAT	Integrated Power Switch	Max. Charging current	VINREG	Power path management	NTC	Cell Balance	Pin #
SC8922	4.5V~5.5V	13.2V	Yes	3A	4.5V	Yes	Yes	Yes	24 pin QFN 4x4
SC8922A	4.5V~5.5V	13.2V	Yes	3A	4.5V	No	Yes	Yes	24 pin QFN 4x4

Note:

SC8922: Support supplement mode with power path function. 1. Only battery exists: Q3 is fully on, which means more quiescent current when only battery exist; 2. System power can be obtained from VSYS pin. What's more, battery will discharge by turning on Q3 fully to satisfy system need when input source capacity is limited (refer to **Supplement Operation**).

SC8922A: No power path function. 1. Only battery exists: Q3 is always off, so IC works under low quiescent current condition; 2. System power can be only obtained from VBAT pin. VSYS pin can't afford system load and it must be connected with 22uF ceramic capacitor. 3. When VIN plug in, Q3 is controlled by charger loop (linear mode in trickle charge; fully on in constant current charge or constant voltage charge), which is same with SC8922.

7 Terminal Configurations and Functions

QFN Top View –SC8922

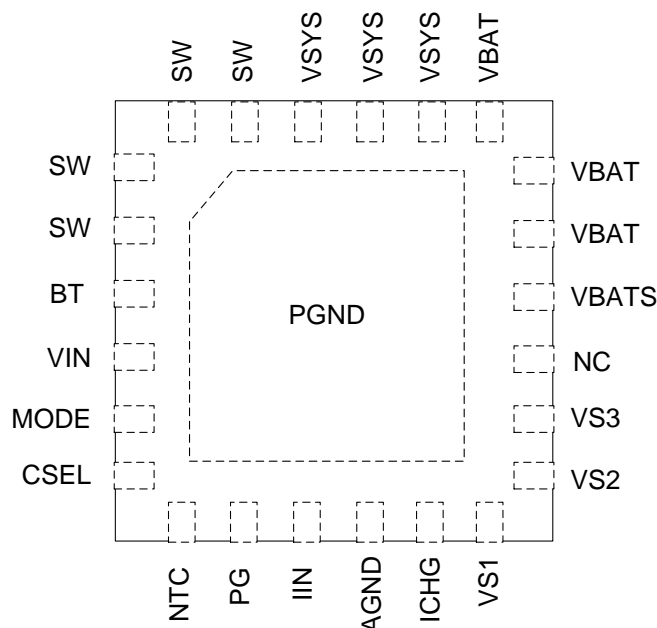

I/O			DESCRIPTION
SC8922	NAME		
3	BT	IO	Bootstrap pin. Connect a 100nF ceramic capacitor between BT pin and SW pin to provide bias voltage for internal driver circuit.
1, 2, 23,24	SW	IO	Switching node of the boost converter. Connect to external inductor.
4	VIN	I	Input of the boost charger
5	MODE	I	MODE selection pin MODE = logic low: auto-termination, cell balance function is enabled. MODE = float: auto-termination, cell balance function is disabled.
6	CSEL	I	Connect a resistor to GND to select the battery termination voltage target
7	NTC	I	Connect to the Negative Temperature Coefficient (NTC) thermistor inside the battery cells to sense the battery cells temperature for protection. Short this pin to ground to disable this function.
8	PG	O	Charging status indication pin. Connect an LED from PG pin and GND pin. It is internally pulled high to indicate the charge in process. When the battery is fully charged, it outputs high impedance and the LED is off.
9	IIN	I	Set the input current limit. IIN = logic high: no input current limit; IIN = float: input current limit is set to 2A; IIN = logic low: input current limit is set to 3A
11	ICHG	I	Connect a resistor to GND to program the battery constant charging current.
10	AGND	IO	Analog ground. Connect PGND and AGND together at the thermal pad under IC.
12	VS1	O	Cell voltage sense and cell balance path
13	VS2	O	Cell voltage sense and cell balance path
14	VS3	O	Cell voltage sense and cell balance path
15	NC		



16, 17, 18, 19	VBAT	O	Output of the boost charger to charge the battery cells.
20, 21, 22	VSYS	O	Output of the boost converter. This pin can provide power for the system operation.
25	PGND	IO	Exposed thermal pad, Connect EP with power ground.

8 Specifications

8.1 Absolute Maximum Ratings

Over operating free-air temperature range (unless otherwise noted)⁽¹⁾

		Min.	Max.	Unit
Voltage ⁽²⁾	VIN, SW, VSYS	-0.3	16	V
	VS3, VBAT	-0.3	14	V
	BT	-0.3	21	V
	MODE, CSEL, NTC, PG, IIN, ICHG	-0.3	5.5	V
	VS2, VS1	-0.3	5	V
T _J	Operating junction temperature	-40	150	°C
T _{stg}	Storage temperature	-65	150	°C

(1) Stresses beyond those listed under absolute maximum ratings may cause permanent damage to the device.

(2) All voltages are with respect to network ground terminal.

8.2 Thermal Information

THERMAL RESISTANCE ⁽¹⁾		QFN-24 (4mmX4mm)	Unit
θ _{JA}	Junction to ambient thermal resistance	39	°C/W
θ _{JC}	Junction to case resistance	9	°C/W

(1) Measured on JESD51-7, 4-layer PCB.

8.3 ESD Ratings

		Min.	Max.	Unit
V _{ESD} ⁽¹⁾	Human-body Model (HBM) ⁽²⁾ All pins	-2	2	kV
	Charged-device Model (CDM) ⁽³⁾	-750	750	V

(1) Electrostatic discharge (ESD) to measure device sensitivity and immunity to damage caused by assembly line electrostatic discharges into the device.

(2) Level listed above is the passing level per ANSI, ESDA, and JEDEC JS-001. JEDEC document JEP155 states that 500-V HBM allows safe manufacturing with a standard ESD control process.

(3) Level listed above is the passing level per EIA-JEDEC JESD22-C101. JEDEC document JEP157 states that 250-V CDM allows safe manufacturing with a standard ESD control process.

8.4 Recommended Operation Conditions

		Min.	Typ.	Max.	Unit
V _{IN}	VIN voltage range	4.5	5	5.5	V
L	Inductor	1	2.2	3.3	μH
C _{IN}	VIN capacitor		10		μF
C _{VSYS}	VSYS capacitor		10		μF
C _{VBAT}	VBAT capacitor	4.7			μF



T_A	Operating ambient temperature	-40		85	°C
T_J	Operating junction temperature	-40		125	°C

9 Electrical Characteristics

Parameter	Description	Test condition	Min.	Typ.	Max.	Unit
Supply and power path						
V _{IN}	Operating input voltage		4.5	5	5.5	V
V _{UVLO}	Under voltage lockout threshold		3	3.2	3.4	V
	Hysteresis		450	550	650	mV
V _{SYS}	VSYS regulation voltage	VBUS = 5V, VBAT = 5V (2 cells)	5.9	6.2	6.5	V
		VBUS = 5V, VBAT = 7.5V (3 cells)	8.835	9.2	9.765	V
V _{SYS_HYS}	VSYS regulation voltage after termination	VSYS_HYS = VSYS - VBAT_TRGT	100	200	300	mV
V _{REF}	Reference voltage		1.176	1.2	1.224	V
V _{SUP}	Q3 VDS regulation voltage in supplement mode			30		mV
I _{Q_VIN}	Quiescent current into VIN pin	Mode pin= float, VIN = 5V, VSYS = VBAT = 8V, non-switching		1.8	3	mA
I _{Q_VBAT}	Quiescent current into VBAT pin	Mode pin= float, VIN = open, VBAT = 8V		65		μA
Power stage						
R _{dson_Q1}	Rdson resistance of Q1	VIN=5V, VSYS=VBAT=8V	31	41	51	mΩ
R _{dson_Q2}	Rdson resistance of Q2	VIN=5V, VSYS=VBAT=8V	22	32	42	mΩ
R _{dson_Q3}	Rdson resistance of Q3	VIN=5V, VSYS=VBAT=8V	30	40	50	mΩ
f _{sw}	Switching frequency		680	800	920	kHz
t _{max_ON}	Maximum on time			5		μs
Charger Function						
I _{CHG}	Constant charging current accuracy	RICHG = 8 kΩ	1.425	1.5	1.575	A
I _{TRK}	Trickle charging current accuracy	RICHG = 12 kΩ, VBAT = 5V	0.1	0.2	0.4	A
I _{TRK_INT}	Internal trickle charge current	RICHG = 0 Ω, VBAT = 5V	0.15	0.3	0.5	A

I _{TERM_INT}	Internal termination charge current		0.075	0.15	0.1725	A
V _{BAT_TRGT}	VBAT target voltage	CSEL = open	8.358	8.4	8.442	V
		CSEL = 300 kΩ	8.514	8.6	8.686	V
		CSEL = 150 kΩ	8.613	8.7	8.787	V
		CSEL = 80 kΩ	8.712	8.8	8.888	V
		CSEL = 40 kΩ	13.068	13.2	13.332	V
		CSEL = 20 kΩ	12.92	13.05	13.181	V
		CSEL = 10 kΩ	12.771	12.9	13.029	V
		CSEL = 0 Ω	12.474	12.6	12.726	V
V _{BAT_TERM}	Termination threshold over VBAT target	Rising edge	96%	98%	99%	
V _{BAT_RECH}	Recharge threshold over VBAT_TRGT	Falling edge	94.05%	95.8%	96.91%	
V _{TRK_CH}	Trickle charge threshold over VBAT target for 2S	Rising edge	5.690	5.8	5.92	V
		Hysteresis	300	400	500	mV
	Trickle charge threshold over VBAT target for 3S	Rising edge	8.53	8.7	8.88	V
		Hysteresis	450	600	750	mV
V _{DPL}	Battery depletion threshold for 2S	Rising edge	4	5	6	V
		Hysteresis		270		mV
	Battery depletion threshold for 3S	Rising edge	6	7.5	9	V
		Hysteresis		270		mV
V _{INREG}	VINREG voltage		4.365	4.5	4.635	V
I _{PG}	Source current at PG pin	VPG = 3V	3	4	5	mA
t _{term_dly}	Termination delay time			1		s

t_{rech_dly}	Recharge delay time			10		ms
t_{safe_timer}	safety timer			24		h
Cell balance						
R_{DS_BLC}	Rdson of balance path		5	7.5	10	Ω
V_{BLC}	Battery cell balance threshold		4.02	4.05	4.08	V
V_{CELL_UVLO}	Battery cell UVLO	2S setting	4.925	5	5.115	V
		3S setting	7.355	7.5	7.675	V
V_{CELL_OVP}	Battery cell OVP protection threshold for each cell	$V_{CELL_OVP} = V_{CELL} - V_{CELL_TRGT}$	20	50	80	mV
		Hysteresis	10	30	50	mV
I_{LIM_IN}	Input current limit	IIN pin float	1.75	1.85	1.95	A
		IIN pin = logic low	2.65	2.8	2.95	A
I_{LIM_PK}	Peak current limit		5.5	6.5	8	A
V_{IN_OVP}	Input over voltage protection	Rising edge	5.8	6	6.2	V
		Hysteresis	0.24	0.3	0.36	V
V_{SYS_OVP}	VSYS over voltage protection	Rising edge, over VSYS target		110%		
		Hysteresis, over VSYS target		5%		
V_{BAT_SC}	VBAT short circuit protection threshold	Falling edge	1.8	2	2.2	V
		Hysteresis	160	200	240	mV
I_{Q3_SC}	Q3 regulation current for short circuit protection		120	200	280	mA
NTC						
I_{BIAS}	NTC bias current		95	102	109	μA
V_{COLD}	NTC cold temp (-5C) threshold	Rising	2.458	2.509	2.560	V
		Hysteresis (falling)	0.15	0.175	0.2	V
V_{HOT}	NTC hot temp (45C) threshold	Falling	0.410	0.435	0.460	V

		Hysteresis (rising)	0.01	0.035	0.06	V
V_{DISNTC}	NTC function disable threshold	Rising	0.07	0.1	0.15	V
		Hysteresis (falling)		0.030		V
t_{NTC_dgl}	NTC status deglitch time			8		ms
LOGIC						
V_{IL}	MODE and IIN input low voltage threshold		0.4		0.7	V
V_{IH}	IIN input high voltage threshold		0.9		1.2	V
Start up						
t_D	Input delay time				5	μ s
$t_{DEBOUNCE}$	Input debounce time	From VIN power up to starting switching			500	ms
t_{SS}	Softstart time	VREF ramp up rate			2	ms
THERMAL						
T_{SD}	Thermal shutdown temperature	Rising		165		$^{\circ}$ C
		Hysteresis		30		$^{\circ}$ C

10 Function Block Diagram

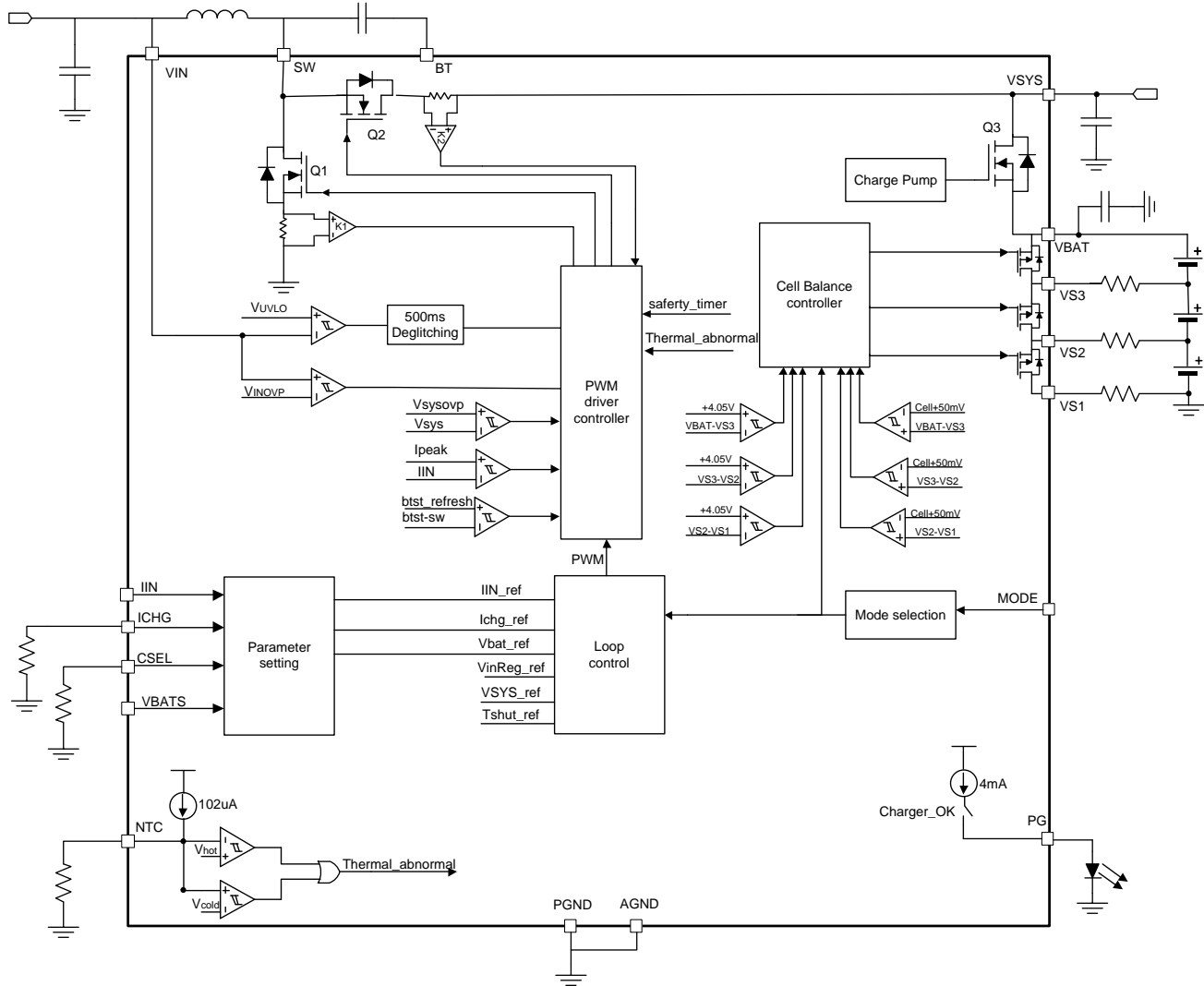

11 Feature Description

11.1 UVLO and Shutdown Mode

The SC8922 is in shutdown when its input voltage is lower than V_{UVLO} threshold. After V_{IN} rises above the UVLO threshold, the IC exits shut down mode to provide power to the system connected at $VSYS$ pin and also charge the battery cells.

When in shutdown mode, if $VBAT$ is higher than the depletion threshold V_{DPL} (typical 5V), the Q3 is fully turned on, so $VSYS$ voltage equals to battery voltage, and the battery can supply the system connected at $VSYS$ pin directly. However, if $VBAT$ is below V_{DPL} , the Q3 will be turned off to disconnect the system from battery. In this case, there is still a path from battery to $VSYS$ pin through the body diode of Q3, and $VSYS$ equals to $VBAT - 0.7V$.

11.2 Soft-Start

After V_{IN} rises above UVLO threshold, there is a 500ms debounce time before the IC starts operation. During the debounce time, there are two scenarios as below:

1. If $VBAT$ is higher than the trickle charge threshold V_{TRK} , the IC keeps Q3 fully on, so the $VSYS$ voltage equals to $VBAT$.
2. If $VBAT$ is lower than V_{TRK} , the IC enables supplement mode, the $VSYS$ voltage equals to $VBAT - 30mV$.

After the 500ms debounce time expires, the IC starts switching and charges the battery in CC mode or CV mode if $VBAT$ is higher than V_{TRK} ; if $VBAT$ is lower than V_{TRK} , the IC ramps up the $VSYS$ to 6.2V for 2s (9.2V for 3s) first, then it turns on Q3 in linear mode to work in trickle charging mode.

The SC8922 integrates an internal soft start circuit which controls the ramp up of the $VSYS$ output and the charge current to the battery cells, preventing inrush current during start-up.

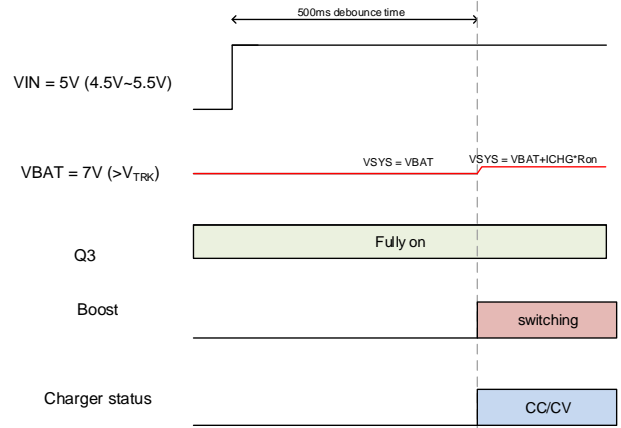

Figure 1 Startup with $VBAT > V_{TRK}$

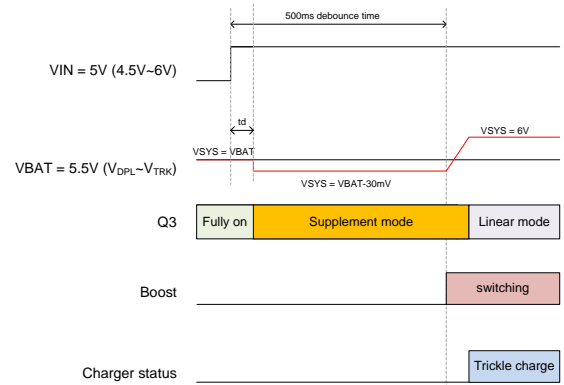

Figure 2 Startup with $VBAT < V_{TRK}$

11.3 Charge management

The SC8922 provides charge management functions for 2~3 cell Li-ion battery. The typical charge profile is shown in Figure 3.

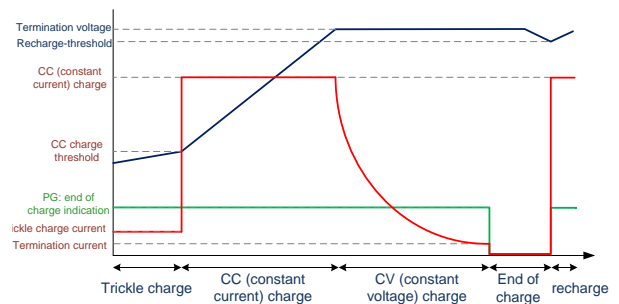

Figure 3 Typical charge profile

11.3.1 Trickle Charge

When $VBAT$ is lower than V_{TRK} , the SC8922 charges the

battery cells in trickle charge mode. In this mode, VSYS is regulated at 6.2V, and Q3 is turned on and works in linear mode. The charge current through Q3 is monitored and regulated at 1/5 of the constant charge current programmed by ICHG pin.

If the 1/5 of the CC current is higher than 300mA, the trickle charge current will be clamped to 300mA.

11.3.2 Constant Current (CC) Charge

When VBAT voltage is charged above V_{TRK} , the SC8922 enters into constant charge (CC) mode. In this mode, the Q3 is fully turned on. The IC monitors Q3 current, and controls the switching duty cycle so to regulate the Q3 current at the CC value programmed by ICHG pin.

11.3.3 Constant Voltage (CV) Charge

The SC8922 operates in constant voltage (CV) mode after VBAT exceeds 98% of the termination voltage target VBAT_TRGT. In CV mode, the Q3 is kept fully on, and the battery voltage is regulated at VBAT_TRGT. The charge current automatically drops until the battery is fully charged.

The battery target voltage can be configured through an external resistor at CSEL pin. Below table shows the relationship between the CSEL resistor value and the VBAT target voltage.

Table 1 CSEL pin to set VBAT target voltage

CSEL Resistor Value	VBAT target voltage
Open	8.4V
300 kΩ	8.6V
150 kΩ	8.7V
80 kΩ	8.8V
40 kΩ	13.2V
20 kΩ	13.05V
10 kΩ	12.9V
0	12.6V

11.3.4 Charge Termination / End of Charge

When below three conditions are valid, the SC8922 recognizes the battery cells are fully charged:

- 1) Termination voltage: the VBAT voltage is higher than 98% of VBAT_TRGT
- 2) Termination current: the Q3 Charge current is lower than 150mA.
- 3) Termination voltage and current condition lasts longer than 1s.

When above three conditions are met together, the SC8922 outputs high impedance at PG pin, so the LED connected at PG pin is off, indicating the end of charge (EOC).

The cell balance status or battery cell OV (over voltage) status is disabled after EOC.

If auto-termination mode is selected, the IC turns off Q3, so to terminate the battery charging. Meantime, it regulates VSYS at VBAT_TRGT + 200mV, keeping supplying current for the system operation.

The IC draws quiescent current from VSYS pin after EOC no matter it is in no-termination mode or auto-termination mode.

11.3.5 Recharge

After EOC, the SC8922 still monitors VBAT voltage. Once it detects the battery voltage falls below 96% of VBAT_TRGT, it turns on Q3 and returns to CC mode again.

11.4 Charging Status Indication

When the SC8922 charges the battery in trickle charge/CC charge/CV charge mode, the PG pin outputs logic high, so the LED connected at PG pin is turned on, indicating the charging is in process.

After the EOC conditions are met, the PG pin outputs high impedance, indicating the battery cells are fully charged.

If the battery voltage drops below the recharge threshold V_{RECH} , the LED will be turned on again.

PG status	IC working status
High logic	Normal charging, Cell Balancing
High impedance	End of charge, Not charging ($V_{IN} < V_{UVLO}$, NTC over/under temperature)
Flashes at 1 Hz	V_{IN} OVP, Battery reverse plug-in

11.5 Constant Charge Current Programming

The constant charge current can be programmed by ICHG pin as below:

$$ICC = K \cdot \frac{VREF}{RICHG}$$

Where,

ICC is the programmed constant charge current

VREF is the internal reference voltage, 1.2V

RICHG is the resistor connected at ICHG pin

K = 10 000

If the ICHG pin is short to ground, the constant charge current is infinite. In this case, the SC8922 relies on input current limit and the internal peak current limit to protect the chip.

11.6 Charge Current Sense

The ICHG pin's voltage is proportional to the Q3 current, so the user can monitor the Q3 charge current through ICHG pin as below:

$$IQ3 = K \cdot \frac{VICHG}{RICHG}$$

Where,

IQ3 is the charge current through Q3

VICHG is the voltage at ICHG pin

RICHG is the resistor connected at ICHG pin

K = 10 000

11.7 Input Current Limit

The SC8922 supports input current limit function, and the limit can be selected by IIN pin as below.

Table 2 Input current selection

IIN input	Input current limit
Logic low	3A
Float	2A
Logic high	Infinite

The IC monitors the input current during operation. Once it detects the input current exceeds the limit, the IC reduces the switching cycle and regulates the input current at the setting value.

11.8 Adaptive Input Current Limit

Besides the input current limit function, the SC8922 supports adaptive input current limit function (VINREG function) to prevent overloading the input adapter.

If the external adapter has smaller current capability than the current the IC draws, IC's VIN voltage will be pulled down. Once the IC detects VIN is pulled below 4.5V, which indicates the adapter can't supply required current, the IC reduces the input current automatically. The input current is reduced to a value which can keep adapter output at 4.5V, so to prevent the adapter from overloading further. This is called adaptive input current limit function or VINREG function.

If the adapter current capability is very low, the IC may enter into burst mode during this operation.

11.9 Supplement Operation

The input power from adapter not only charges the battery but also supplies current for the system operation at VSYS pin.

If the system draws very heavy load, the input current satisfies system first, and the extra current charges the battery. In this case, the IC operates in the input current limit or VINREG status.

If the system needs more power than what input can supply, the VSYS voltage will be pulled down by the load. In this case, the Q3 keeps fully on, so the battery is discharged through Q3 to supply the system, and VSYS is equal to VBAT;

When in EOC status with Q3 off (auto-termination mode), VSYS is regulated at VBAT_TRGT+200mV. The Q3 will be turned on when VSYS is pulled lower than VBAT, so to supplement the current to system. In this case, the Q3 gate is regulated so that the minimum Q3 VDS stays at 30 mV when the current is low. This prevents oscillation from entering and exiting the mode. As the discharge current increases, the Q3 gate is regulated with a higher voltage to reduce its R_{DS(ON)} until the Q3 is in full conduction. At this point onwards, the Q3 VDS linearly increases with discharge current.

11.10 Cell Balance

When the MODE pin is pulled high or low, cell balance function is enabled.

Table 3 Mode selection

MODE input	Cell balance	Termination
Float	Disabled	Auto-termination
Logic low	Enabled	Auto-termination

When the cell-balance function is enabled, the SC8922 keeps monitoring each cell voltage through VSx pins. Once it detects there is one or more cells voltages are above 4.05V, but there is another or more cells voltage below 4.05V, it turns on the cell discharging paths for the cells above 4.05V. The cell balance will be deactivated when

1. all cells' voltages are above 4.05V, or
2. all cells' voltages are below 4.05V

The balance discharge path will also be turned on when any cell's voltage is detected higher than OVP threshold (50mV higher than the termination target voltage). External resistors are necessary as below to control the discharging current. 10~100Ω resistors (1206 footprint) are suggested for each cell as below:

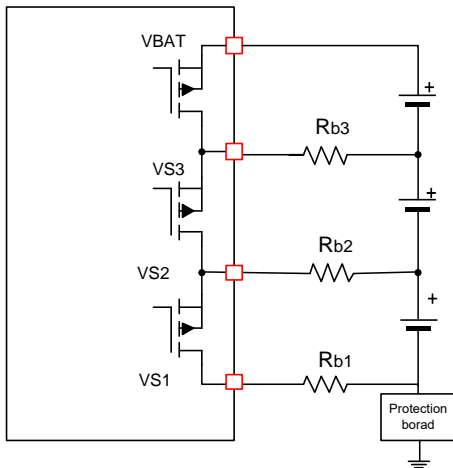

Figure 4 Cell balance circuit

Balance current of each cell can be calculated as follow:

$$I_{b3} = \frac{V_{cell3}}{R_{b3} + R_{dson}}$$

$$I_{b2} = \frac{V_{cell2}}{2 * R_{b2} + R_{dson}}$$

$$I_{b1} = \frac{V_{cell1}}{2 * R_{b1} + R_{dson}}$$

Where,

Vcellx is voltage of OV cell.

Ibx is balance current.

Rbx is balance resistor.

Rdson is conducting resistance of internal FETs.

Cell balance is disabled after termination;

Cell balance is disabled after VIN drops below UVLO or VBAT drops below POR (Three cells is 7.5V and two cells is 5V).

If MODE is left floating to disable the cell balance function, VS3/VS2/VS1 can be floating.

If larger cell balance current is required to accelerate balance time, external mosfet can be used to enhance balance effect.

PMOS can be used in 2 cells applications. Balance current is mainly decided by external resistor Rbx. The Vth of PMOS should be lower than -2V, to ensure balance circuit work normally. What's more, larger balance current may cause thermal issues, so Rbx resistor must be carefully chosen to satisfy requirement of system heat dissipation. Balance current of each cell can be calculated as follow:

$$I_{bx} = \frac{V_{cell}}{R_{bx}}$$

Where,

Rbx is the external resistor of each balance path.1kΩ is recommended value for Rx.

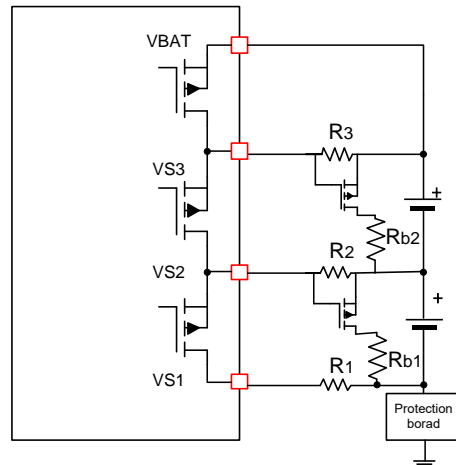

Figure 5 PMOS for 2 Cells balance circuit

Similarly, NMOS can be also used in 2 cells applications. The Vth of NMOS should be lower than 2V.

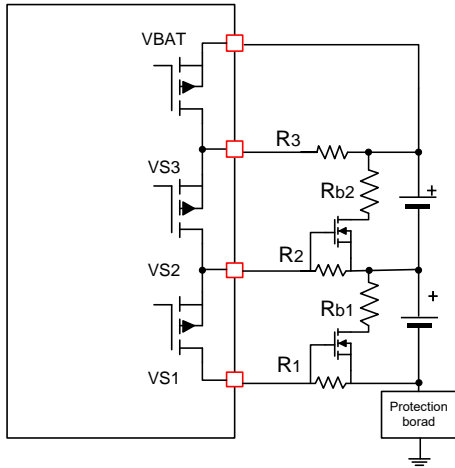

Figure 6 NMOS for 2 Cells balance circuit

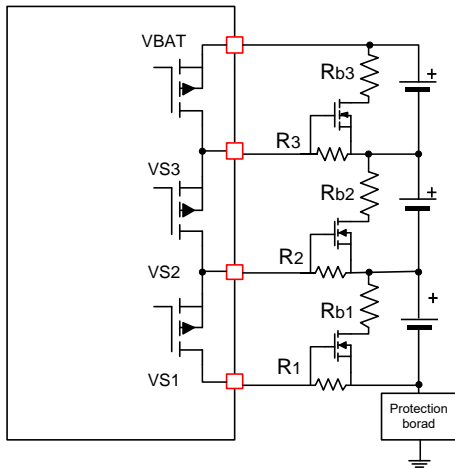

Figure 7 NMOS for 3 Cells balance circuit

11.11 VBAT Over Voltage Protection

With the cell balance enabled, the SPIDERMAN monitors each cell's voltage through VSx pins. Once it detects any cell's voltage is 50mV higher than the termination target voltage, it stops charging and turns on the discharging path for that cell. Only when the cell's voltage drops below the OVP threshold, the IC recharges the battery cells again.

11.12 Input Over Voltage Protection

Besides under voltage protection, the SC8922 also supports input over voltage protection. Once the IC detects the input voltage is higher than 6V, it stops switching, turns off Q3 and PG flashes at 1Hz. After the input voltage drops

below the threshold, it resumes the normal operation.

11.13 VSYS Over Voltage Protection

The SC8922 monitors VSYS voltage during the operation. Once it detects the VSYS is higher 110% of the target voltage, over voltage protection will be triggered, and the IC stops switching at once. After the VSYS voltage drops below 103% of the target, it resumes switching. Q3 status will not be affected by VSYS OVP.

11.14 VBAT Short Circuit Protection

Once the IC detects the VBAT voltage drops below 2V, the short circuit protection is triggered. The IC turns on Q3 in linear mode and regulates the short current to 200mA. Meantime, the IC regulates the VSYS at 6V.

After the short circuit fault is removed, the VBAT voltage is charged up. When VBAT voltage is higher than the short circuit threshold, the IC returns to normal operation.

11.15 Safety Timer

When the IC starts charging (VIN above VINREG threshold), a 24-hours safety timer is initiated. Once it detects EOC condition, the IC clears the timer, and it doesn't restart the timer unless recharge phase starts, or VIN toggle happens.

If the charging cycle doesn't end when the timer expires, the IC will transition to shutdown mode. In this case, the IC will only restart the timer after VIN toggles.

11.16 NTC

The SC8922 monitors the battery cells' temperature through NTC pin once VIN is above ULVO threshold. It sources 102 μA current to NTC pin and monitor the NTC voltage. Once it detects the temperature is below -5°C or higher than 45°C, the IC transitions to shutdown mode. Below shows the NTC operation summary. NTC function can be also disabled through shorting the pin to ground.

Table 4 NTC operation

V_{NTC}	Temperature	Operation
$V_{NTC} > V_{COLD}$	$T < -5^{\circ}\text{C}$	Stop charging
$V_{HOT} < V_{NTC} < V_{COLD}$	$-5^{\circ}\text{C} < T < 45^{\circ}\text{C}$	Normal charging
$V_{DISNTC} < V_{NTC} < V_{HOT}$	$T > 45^{\circ}\text{C}$	Stop charging

11.17 Thermal shutdown

Once the SC8922 detects the junction temperature rises



above 165°C, it shuts down the whole chip. When the temperature falls below 135°C, the chip is enabled again.

12 Application information (TBD)

12.1 NTC Resistor Selection

SC8922 continuously monitors battery temperature by measuring the NTC voltage. An internal 102µA current source provides the bias for NTC thermistors. The device compares the NTC pin voltage V_{NTC} with the internal V_{COLD} and V_{HOT} thresholds (refer to electrical characteristics) to determine whether charging is allowed.

$$R_{cold} = \frac{V_{cold}}{102\mu A} = 24.6k\Omega$$

$$R_{hot} = \frac{V_{hot}}{102\mu A} = 4.6k\Omega$$

With a 103AT-type thermistor, the default charger operating temperature range is 3°C to 45°C.

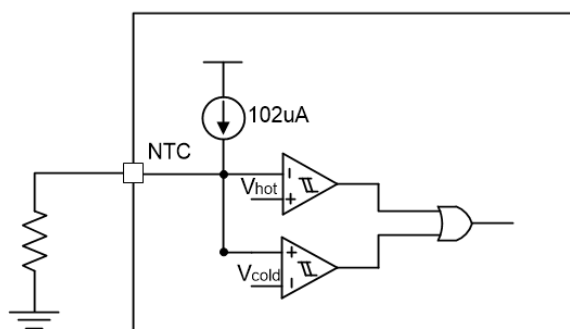

Figure 8 Default NTC thresholds

The external resistor can be used to change charger operating temperature range. For example, in order to change operating temperature to 0°C to 60°C.

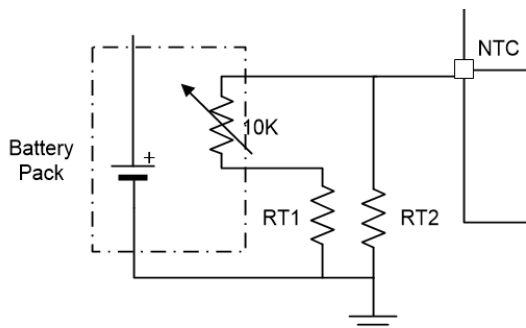

Figure 9 Threshold changed by external resistor

$$\frac{(R_{0^{\circ}C}+RT1)*RT2}{R_{0^{\circ}C}+RT1+RT2} = 24.6k\Omega$$

$$\frac{(R_{50^{\circ}C}+RT1)*RT2}{R_{50^{\circ}C}+RT1+RT2} = 4.6k\Omega$$

For a 103AT-type thermistor, $R_{0^{\circ}C} = 28.71k\Omega$, $R_{50^{\circ}C} = 2.99k\Omega$. so $RT1$ and $RT2$ is calculated:

$$RT1 = 1.78k\Omega$$

$$RT2 = 127k\Omega$$

Besides, NTC pin can be used as enable pin function alternatively. The reference circuit is as follow:

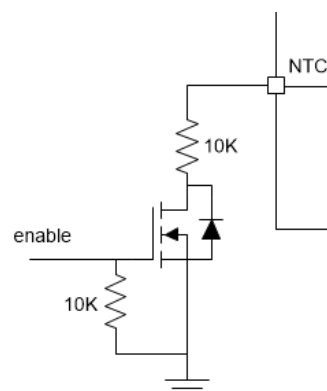

Figure 10 NTC pin used as enable function

12.2 Capacitor Selection

Since MLCC ceramic capacitor has good high frequency filtering with low ESR, above 22µF X5R or X7R capacitors with higher voltage rating than operating voltage with margin is recommended. For example, if the highest operating V_{in} voltage is 6V, select at least 10V capacitor and to secure enough margin, 16V voltage rating capacitor is recommended.

The high capacitance polymer capacitor or tantalum capacitor can be used for input and output, but capacitor voltage rating must be higher than the highest operating voltage with enough margin. The recommended capacitance polymer capacitor is at least 100µF to ensure loop stability. The high frequency characteristics of these capacitors are not as good as ceramic capacitor, so at least 10µF ceramic capacitor should be placed in parallel to reduce high frequency ripple.

12.3 Inductor Selection

1 µH to 3.3 µH inductor is recommended for loop stability. Choose the inductance to provide the desired ripple

current. The current ripple is calculated as:

$$I_{ripple} = \frac{V_{IN} * (V_{OUT} - V_{IN})}{V_{OUT} * F_{SW} * L}$$

It is suggested to choose inductor ensure the ripple current to be about 40% of the average input current I_{IN} .

When selecting inductor, the inductor saturation current must be higher than the peak inductor current with enough margin (20% margin is recommended).

$$I_{peak} = I_{IN} + \frac{V_{IN} * (V_{OUT} - V_{IN})}{2 * F_{SW} * L * V_{OUT}}$$

Where I_{IN} is the input current, and can be calculated as:

$$I_{IN} = \frac{V_{OUT} * I_{chg}}{V_{IN} * \eta}$$

η is the efficiency of boost converter.

The inductor DC resistance value (DCR) affects the conduction loss of switching regulator, so low DCR inductor is recommended especially for high power application. The conductor loss of inductor can be calculated roughly as:

$$P_{LDC} = I_{IN}^2 * DCR$$

I_{IN} is the average value of inductor current.

12.4 Layout Guide

1. The capacitors connected at VIN/VSYS/VBAT pins should be placed near the IC, and their ground connection to the ground pins should be as short as possible. Especially VSYS capacitor must be placed carefully to ensure better performance.

a. component(s) on schematic:

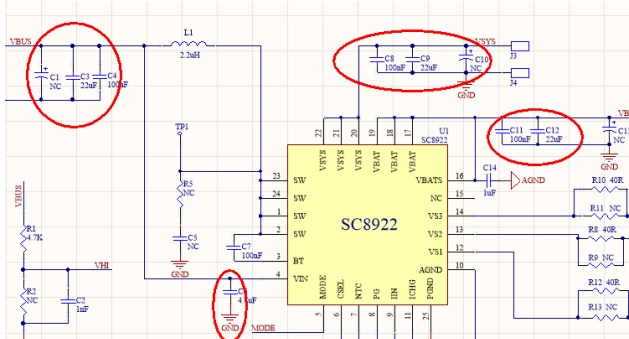

b. **Layout example:** put the input and output capacitors near IC but on the bottom layer. Connect the capacitors to each pin through vias and connect the capacitors to ground pins by the ground pour.

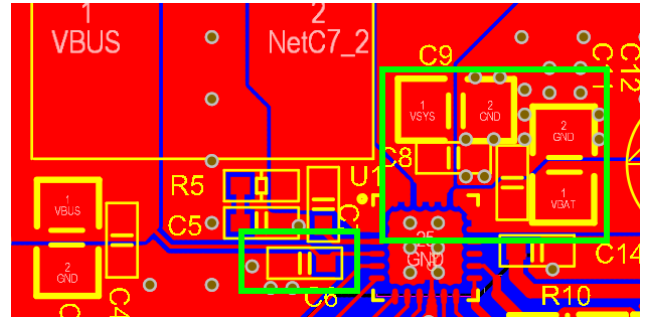

2. It is suggested that PGND and AGND are connected at the PGND pad under IC.

a. component(s) on schematic:

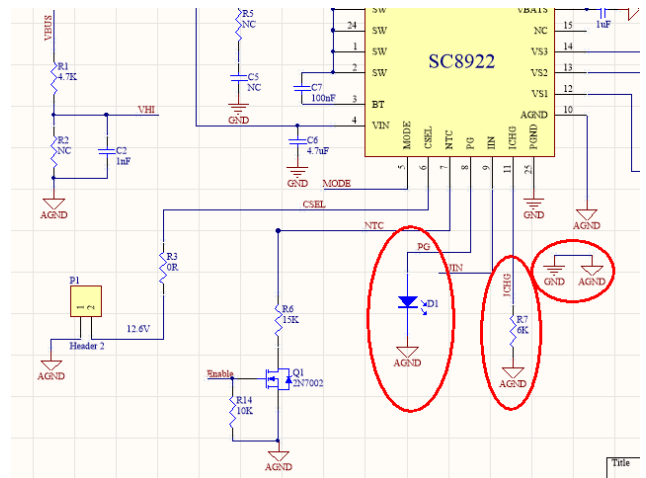

b. Layout example:

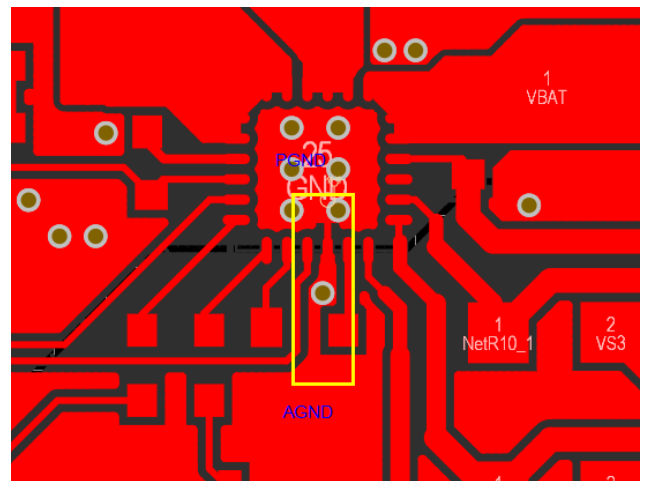

3. The cell balance path wire should be at least 10mil to endure cell balance current.

12. MECHANICAL DATA

QFN (4mmx4mmx0.75mm)

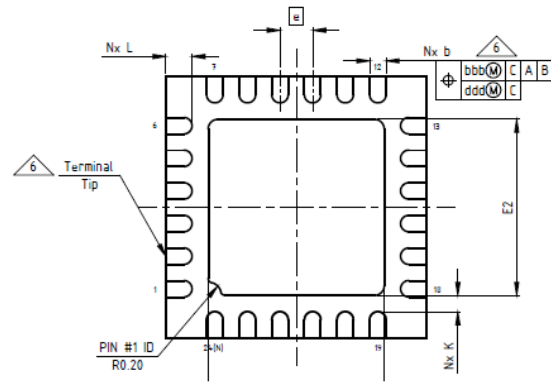
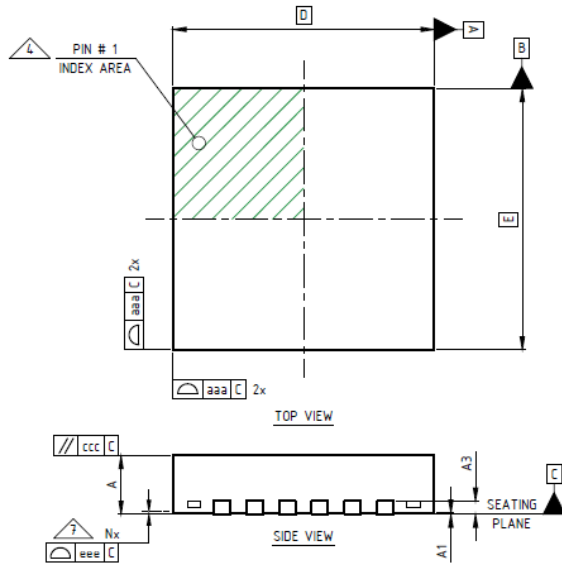

Dimension Table				
Thickness Symbol	W			NOTE
	MINIMUM	NOMINAL	MAXIMUM	
A	0.70	0.75	0.80	
A1	0.00	0.02	0.05	
A3	---	0.20 Ref.	---	
b	0.18	0.25	0.30	6
D	4.00 BSC			
E	4.00 BSC			
e	0.50 BSC			
D2	2.55	2.70	2.80	
E2	2.55	2.70	2.80	
K	0.20	---	---	
L	0.30	0.40	0.50	
aaa	0.05			
bbb	0.10			
ccc	0.10			
ddd	0.05			
eee	0.08			
N	24			3
ND	6			5
NE	6			5
NOTES	1, 2			